

# 1" DRIP EDGE

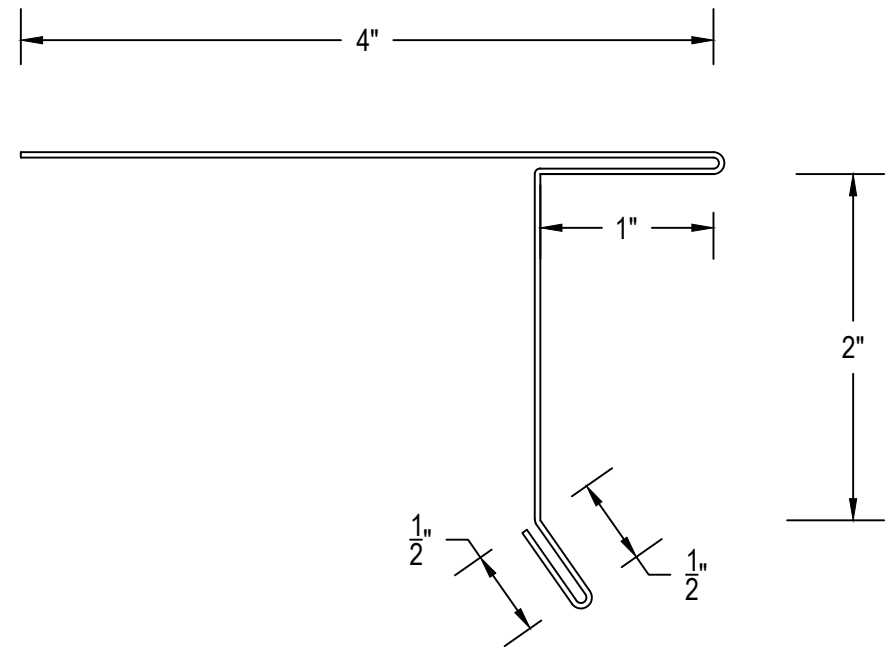

MATERIAL (please choose one):

- |  |  |
|--|--|
| <input type="checkbox"/> 24 GA Steel   | <input type="checkbox"/> .040 Aluminum |
| <input type="checkbox"/> 22 GA Steel   | <input type="checkbox"/> .050 Aluminum |
| <input type="checkbox"/> .032 Aluminum | <input type="checkbox"/> .063 Aluminum |

Other: \_\_\_\_\_  
 Color: \_\_\_\_\_  
 Finish: \_\_\_\_\_

QUANTITIES:

\_\_\_\_\_ Total Linear Feet (10'-0" Lengths)

Miter/End Cap Fabrication Requirements:

- |   |   |
|---|---|
| <input type="checkbox"/> Pop Rivet & Sealed | <input type="checkbox"/> Welded (see note)* |
|---|---|

Installation:  
 1) Fastened at 6" O/C minimum or otherwise noted.  
 2) 1.5" SS Ring Shank nails, minimum  
 3) Splice plates require 2 beads of sealant per side at splice

Sheet \_\_\_ of \_\_\_. DWG# 730-003

Notes:  
 1) \*Accessory Welding is only available in .040 aluminum or heavier.  
 2) External splice plates are available upon request.  
 3) Written approval is required prior to fabrication, contractor is responsible for all dimensions and quantities. Fabricated items are not returnable.

Project Name: \_\_\_\_\_  
 Installing Contractor: \_\_\_\_\_  
 Contact Name: \_\_\_\_\_  
 Contact number: \_\_\_\_\_  
 Signed Approval: \_\_\_\_\_

Temple Architectural Products  
 1111 Lowell St.  
 Elyria, Ohio 44035  
 (440) 323-9393  
 Estimates@templearchitecturalproducts.com  
 www.templearchitecturalproducts.com